



SHANGHAI OE INDUSTRIAL CO., LTD.



# SHANGHAI OE INDUSTRIAL CO., LTD.

## 2025 COMPANY PROFILE

## TABLE OF CONTENT

---

Company Overview	03	Key Solutions	12
Company Milestone	08	Product Portfolio	20
Our Global Presence	09	Our Factories	22
Meet The Team	10	Our Projects	27
How We Work	11	Contact Us	29



## COMPANY OVERVIEW

---

### Who we are

Established in 2011, Shanghai OE Industrial Co., Ltd. (brand: Brogen) has become a globally recognized leader in advanced EV systems. Initially focused on the global supply of high-quality automotive components, Brogen has strategically evolved to meet the growing demand for green transportation solutions driven by environmental priorities.

Since 2019, Brogen has specialized in delivering customized, eco-friendly EV systems and services to automotive manufacturers worldwide. This transition reflects our dedication to advancing sustainable mobility while addressing the industry's need for innovative, reliable, and environmentally responsible technologies.

With a steadfast commitment to quality and innovation, Brogen continues to be a trusted partner in shaping the future of electrified transportation globally.

### What we do

We provide modular EV systems for diverse applications, including urban delivery, public transportation, heavy-duty haulage, and construction equipment. Serving automotive manufacturers and EV tech firms, our solutions are tailored to meet unique needs and help customers succeed in the rapidly growing EV market.





# MISSION, VISION, VALUE

---

## Mission

To accelerate the transition to green renewable energy, facilitate early global carbon neutrality, and promote the advancement of human society.

## Vision

To be the premier provider of world-class green renewable energy solutions and services, enabling all stakeholders - customers employees, shareholders, and business partners - to pursue and achieve their aspirations.

## Value

Uphold integrity and honesty;  
Embody both virtue and competence;  
Foster innovation and collaboration;  
Strive for excellence and continuous improvement.





# COMPANY STRENGTH



## Strong R&D Capabilities

Our robust R&D capabilities allow us to deliver custom, project-specific EV systems tailored to meet unique customer requirements.

## Extensive Product Range

Our diverse product portfolio accelerates project timelines, streamlining the sourcing process and reducing costs for our clients.

## Global Expertise

We have extensive experience handling multinational projects, providing reliable support to clients across the globe.



## Strategic Partnerships

We collaborate with hundreds of world-class partners in the industry, ensuring access to the latest technologies and high-quality components.

## Flexible Procurement Options

We offer flexible ordering solutions, including small-batch orders, to accommodate specific client needs and project requirements.

## Multilingual Support

Our multilingual sales teams (English, Japanese, Korean, German, and French) ensure smooth communication and minimize language barriers.

## COMPANY DEVELOPMENT

With rapid growth year on year, we project a 200% increase in business this year. Our journey, from humble beginnings to impactful projects, has been powered by passion, dedication, and an unwavering commitment to sustainability. We are excited to continue our mission as a leading provider of innovative EV solutions, driving the transition to clean, electrified transportation.

- 14+** years of EV industry experience
- 30+** countries of product presence
- 350+** global clients

### Annual Revenue Growth

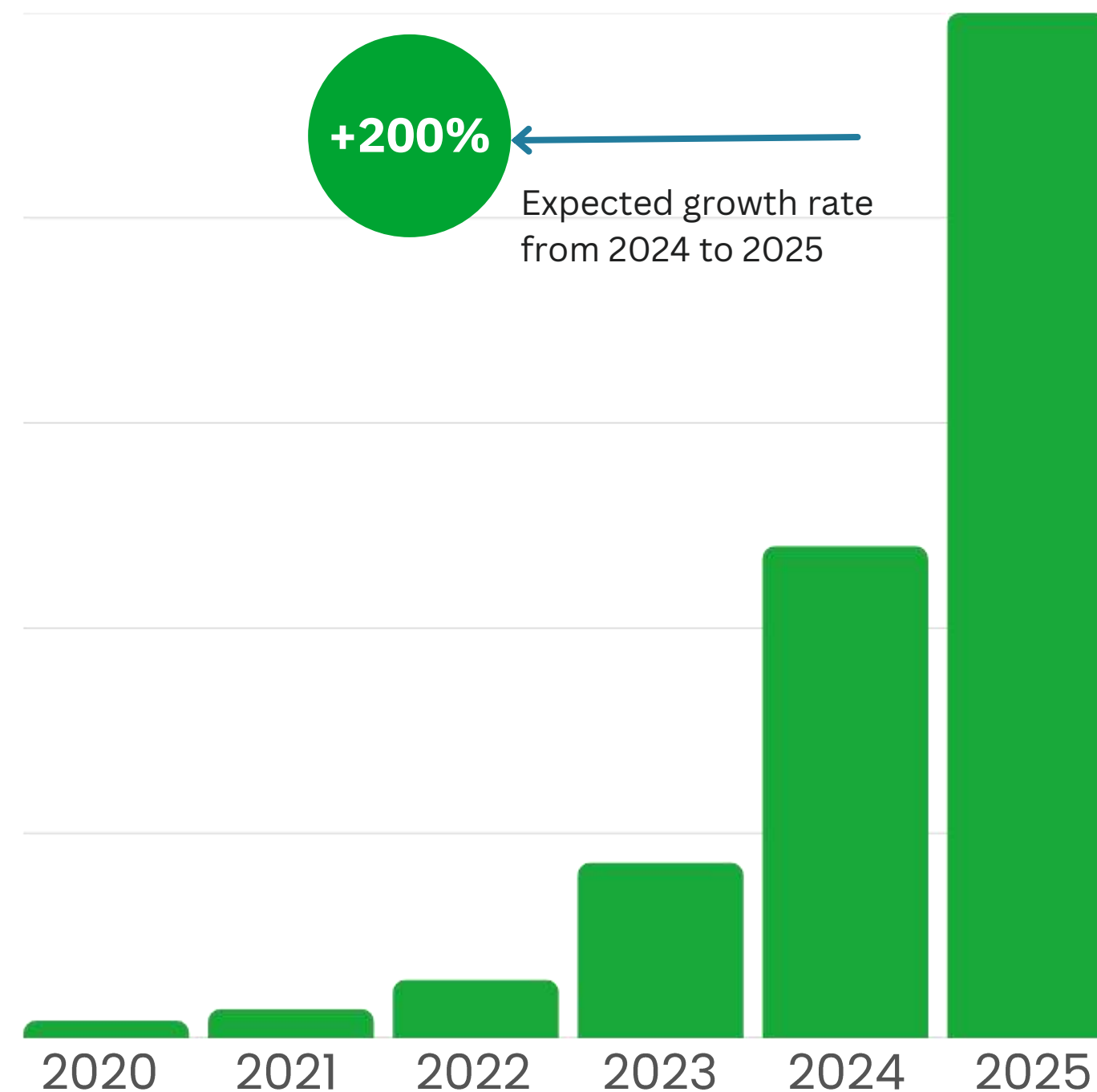



# PRODUCT SALES PROPORTION

- E- Powertrain
- EV Batteries
- Chargers & Converters
- Power Steering Systems
- Braking Systems
- Others

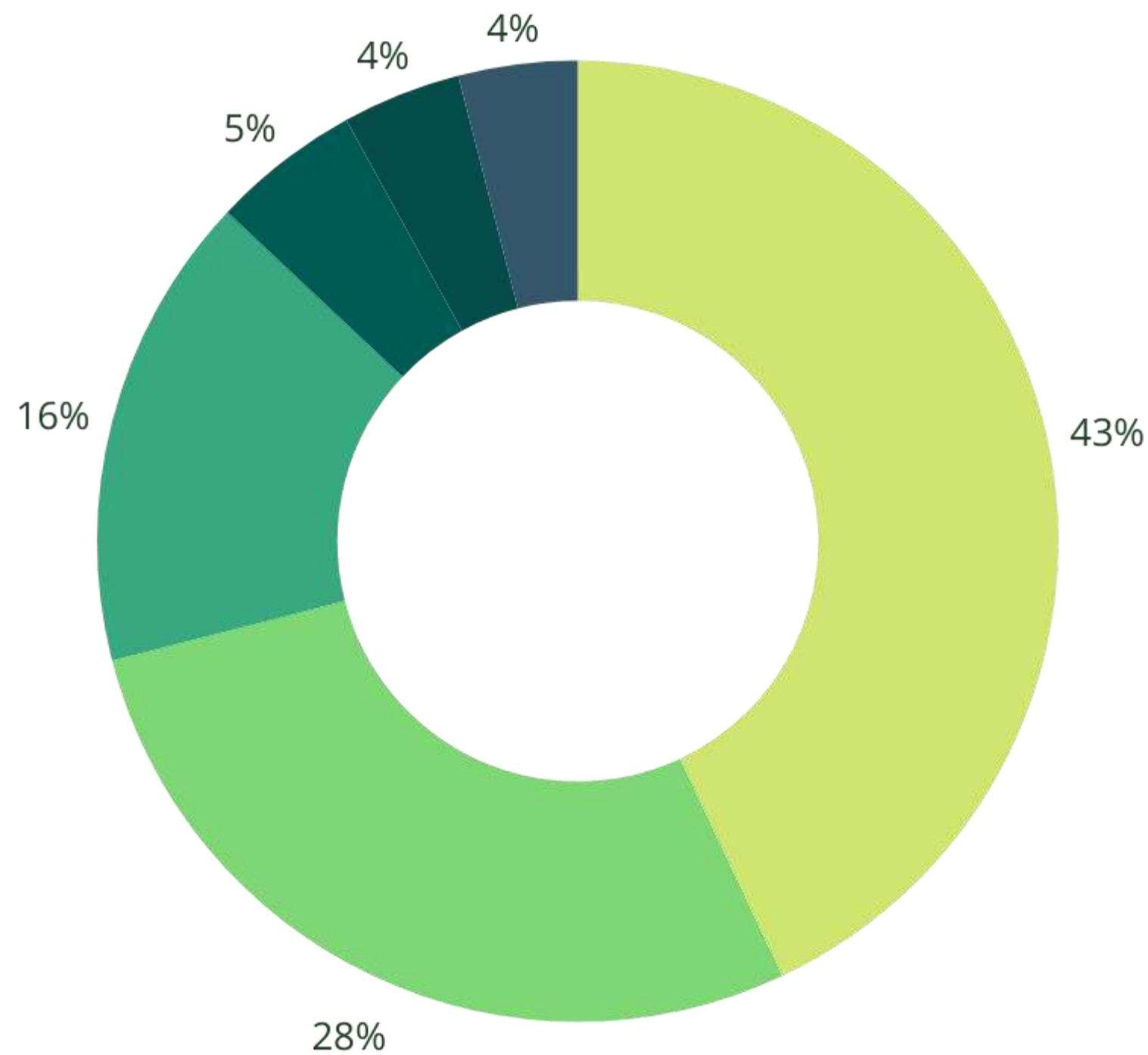

# COMPANY MILESTONE



**2024**

We have secured a major contract worth over \$30 million with a key customer, paving the way for deeper partnerships.



**2023**

We have invested in an e-axle factory and were recognized by Alibaba Group as Global Top Supplier in the EV industry.



**2022**

We supplied traction power and battery systems for Spain's first electric boat project, underscoring our commitment to sustainability.



**2017**

We invested in several EV parts factories, including an EPS factory, strengthening our collaboration in the EV industry.



**2011**

With extensive experience in the automotive industry, CEO Henry Liao founded the company, making its entry into the new energy sector.



Certificate





# OUR GLOBAL PRESENCE

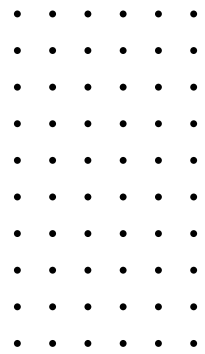

Our EV systems are currently in operation across more than 30 countries, powering buses, trucks, trailers, and ships. These systems have played a key role in helping global EV builders successfully execute their projects, proving their reliability and safety in diverse conditions. With a strong track record in reducing carbon emissions, our solutions are helping accelerate the transition to greener, more sustainable transportation. By supporting the success of our partners worldwide, we're contributing to a cleaner, more efficient future for mobility.

# MEET THE TEAM

Our team has extensive experience in EV projects worldwide and is dedicated to propelling your business to new heights. We adhere to an integrity-based, customer-first philosophy, focusing on quality and the pursuit of excellence. With our wealth of experience and fresh perspectives, we bring exceptional value to every project.

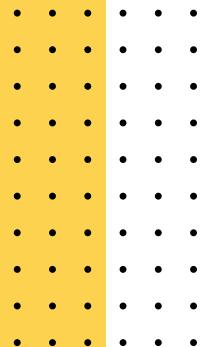
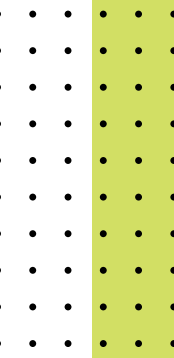

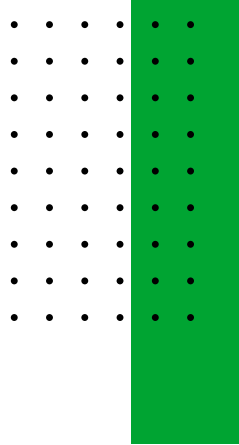

# HOW WE WORK

We have developed a comprehensive and well-structured project engagement service system designed to support your project at every stage, from pre-sales consultation to in-sales execution and post-sales support.

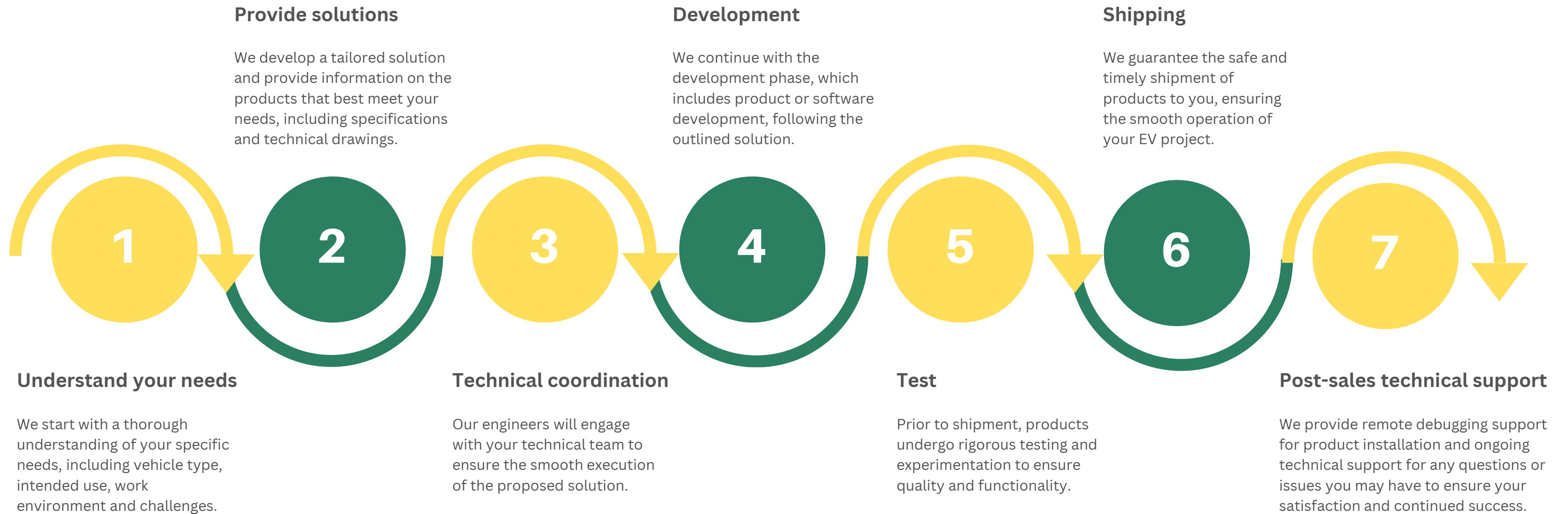



## KEY SOLUTIONS

Leveraging our industry expertise, we offer comprehensive systems that benefit both EV manufacturers and fleet operators. Our solutions accelerate R&D and reduce manufacturing footprint for OEMs, while fleet operators benefit from increased efficiency, reduced emissions, and minimized downtime for maintenance.

### Powertrain

- **30 kW ~ 900 kW**
- PMSM motor
- Improved system efficiency
- Space & weight savings
- High safety & reliability
- Simplified vehicle layout

### EV Battery

- **10 kWh ~ 2000 kWh**
- LFP / NMC
- High energy density
- Space & weight savings
- High safety & reliability
- Flexible & customizable

### Chargers & Converters

- **3.3 kW ~ 40 kW OBC**
- X-in-1 integrated system
- Wide voltage output range
- Efficient thermal management
- Excellent heat dissipation
- Comprehensive protection

### EV Chassis

- **Class 1 to Class 8 truck**
- 6-meter to 18-meter bus
- Adapt to various vehicle types and payloads
- Flexible customization options
- Driver-centric design for enhanced experience

# FOR LCV

Electric light commercial vehicles are critical to the commercial vehicle market, especially with the rise of electric vehicles. Our modular EV systems for LCVs streamline production and operations, saving time and money while increasing efficiency and market competitiveness.

Motor + Controller + Gearbox (optional)



- 60 kW ~ 165 kW
- PMSM motor
- Minimize chassis modification
- Efficient transition plan

Electric Axle



- 60 kW ~ 165 kW
- PMSM motor
- Optimizing vehicle layout
- High system transmission efficiency

EV Battery



- 33 kWh ~ 100 kWh
- LFP battery
- High energy density
- Flexible & customizable

EV Chassis



- Class 1 ~ Class 3 truck
- Adapt to various vehicle types and payloads
- Flexible customization options
- High integration



## FOR HCV

For heavy commercial vehicles, we offer a comprehensive range of EV systems designed to significantly enhance fleet operational efficiency while elevating safety standards in heavy-duty transportation.

### Motor + Controller + Gearbox (optional)



- 165 kW ~ 800 kW
- PMSM motor
- Minimize chassis modification
- Efficient transition plan

### Electric Axle



- 360 kW ~ 500 kW
- PMSM motor
- Optimizing vehicle layout
- High system transmission efficiency

### EV Battery



- 180 kWh ~ 600 kWh
- LFP battery
- High energy density
- Flexible & customizable

### EV Chassis

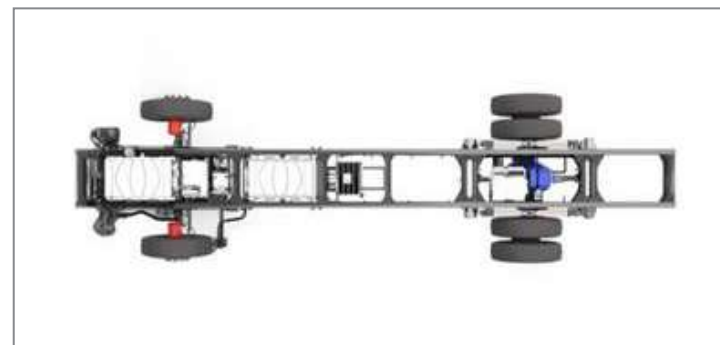

- Class 3 ~ Class 8 truck
- 20% fuel savings and CO<sub>2</sub> emissions reduction
- Flexible customization options



# FOR PUBLIC TRANSPORT

Aligned with industry trends, our EV solutions support bus and coach manufacturers, fleets, and public transport agencies in transitioning toward zero emissions, zero accidents, and improved efficiency.

Motor + Controller + Gearbox (optional)

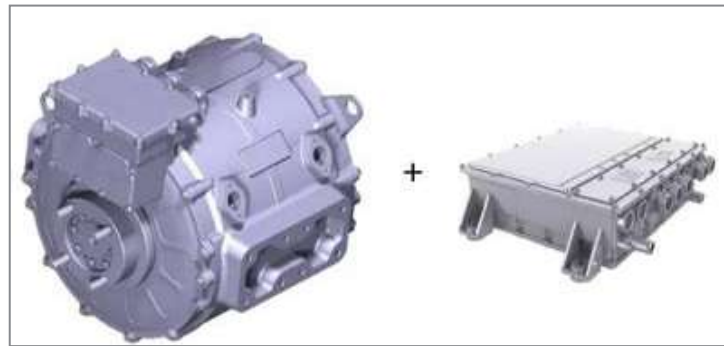

- 130 kW ~ 400 kW
- PMSM motor
- Improve passenger comfort
- Easier maintenance

Electric Axle



- 180 kW ~ 320 kW
- Adaptable to the low-floor design
- Distributed drive system
- Extra safety redundancy

EV Battery



- 180 kWh ~ 420 kWh
- LFP battery
- High energy density
- Flexible & customizable

EV Chassis



- 6-meter ~ 18-meter
- Compliance with stringent safety standards
- Precision cable and wiring layout
- CAN-BUS electrical control mode



## FOR OFF-HIGHWAY VEHICLES

Our EV solutions for off-highway vehicles, including construction machinery like forklifts and dump trucks, create a safer and greener working environment.

Motor + Controller



- Available for specialty vehicle upfitting
- PMSM motor
- High power efficiency
- Adapt to harsh working conditions

EV Battery



- **180 kWh ~ 600 kWh**
- LFP battery
- High energy density
- Flexible & customizable



## FOR VESSELS

Contributing to the construction of an eco-civilization on water, our vessel solutions provide safe, reliable, green and environmentally friendly options.

Motor + Controller



- Powerful performance
- High system efficiency
- Compact and lightweight design
- Adapt to harsh working conditions

EV Battery



- **90 kWh ~ 2000 kWh**
- Efficient liquid cooling & heat dissipation
- Independent & safe pre-processing
- Flexible & customizable





## OTHER SOLUTIONS



### On-board Charger

- 3.3 kW ~ 40 kW
- Single OBC; 2-in-1 OBC+DCDC; 3-in-1 OBC+DCDC+ PDU
- Adapt to high-voltage platforms
- Excellent heat dissipation
- Wide voltage output range

### Inverter

- X-in-1 compact system with DC/DC converter, DC/AC inverters, and PDU
- Robust design for harsh operating conditions
- Quiet operation for minimal disruption
- Flexible to accommodate various vehicle types and configurations
- Reduce redundant components for cost savings and operational efficiency



## OTHER SOLUTIONS



### EHPS

- Integrated compact design
- Configurable operating modes via CAN communication
- Flexible development and wide applicability
- Multi-variable fuzzy control
- Temperature monitoring
- Dual source for additional safety redundancy

### EPS

- Light & responsive steering
- Flexible system layout
- Low noise, high comfort & active safety
- Fast matching and rapid development
- Compatibility with ADAS and autonomous driving



### RCB

- High transmission efficiency
- Easy and comfortable to operate
- Less wear on mechanical parts
- Long service life

## OTHER SOLUTIONS



### Air Brake Compressor

- Self-lubricating materials for oil-free compression
- Two-stage compression system
- Advanced noise reduction technology
- Shock absorption for smooth operation with minimal vibration
- Broad applicability and robust versatility

### BTMS

- Efficient heat dissipation
- Accurate battery measurement and monitoring
- Battery preheating for improved low-temperature charge/discharge performance and safety
- Temperature equalization to reduce thermal disparities and extend overall battery pack life



# PRODUCT PORTFOLIO



Motor



eAxle



Controller



EV Battery



BTMS



EHPS



EPS

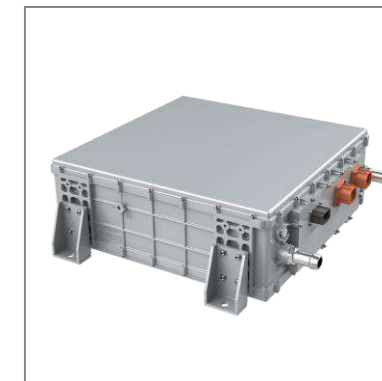

OBC | DC/DC | PDU

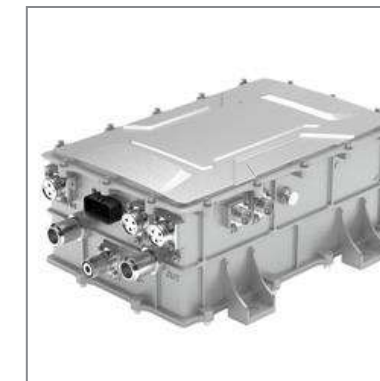

Auxiliary Inverter



AC Compressor



Air Brake Compressor



Water Pump



Bus Air Conditioner



EV Chassis



## OUR OFFERINGS

Products	Car	Truck	Bus	Ship	Off-highway Vehicle	Remark
PMSM Motor	√	√	√	√	√	Based on our discussion, we will recommend the appropriate motor and controller for your needs. We don't supply controllers separately. If needed, some solutions integrate the motor, controller, and gearbox into a 3-in-1 system.
Controller	√	√	√	√	√	
Gearbox	√	√				
Electric Axle		√	√			E-axle with single motor, dual motor, independent controller, 2-in-1 controller
EV Battery	√	√	√	√	√	We offer battery cells, modules, and packs. We don't do personal projects.
Battery Thermal Management System		√	√			
EV Chassis	√	√	√			
OBC	√	√	√			Single OBC, 2-in-1 OBC+DCDC, 3-in-1 OBC+DCDC+PDU
DC / DC Converter	√	√	√			
PDU	√	√	√			
Auxiliary Inverter		√	√			
EPS	√	√	√			For new vehicle development projects.
EHPS	√	√	√			For conversion projects.
Air Brake Compressor		√	√			
Water Pump	√	√	√			
Vacuum Pump	√					
Air Conditioning System	√	√	√			
Harness Wire (High Voltage)	√	√	√			If the quantity is small, it cannot be provided.

# MOTOR FACTORY

## R&D

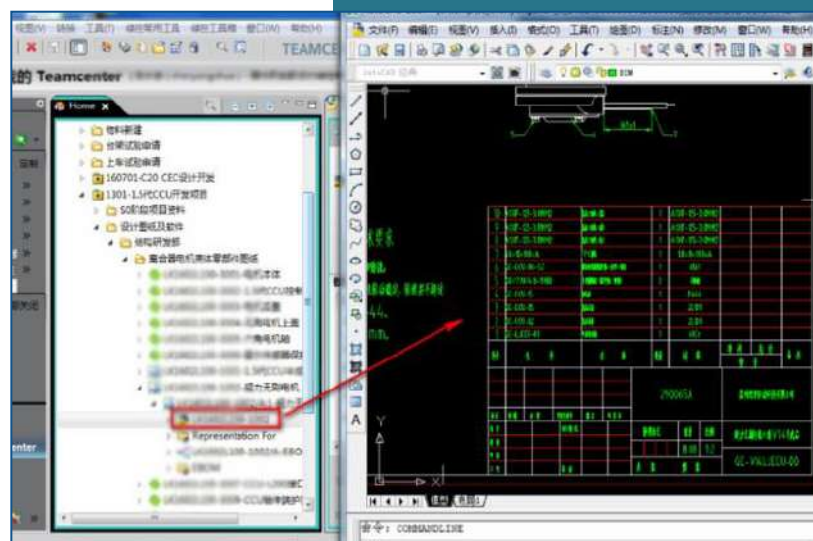

We have full-cycle validation capabilities for product development, from individual components to complete assemblies. Our rigorous testing process, including bench tests and vehicle trials, ensures continuous improvement and reliable performance. With over 100 advanced testing devices, 20+ test vehicles, and a robust experimental process, we validate products through a range of tests, including immersion, temperature extremes, salt spray, vibration, durability, noise, and road tests. This ensures excellent reliability, cost-efficiency, power, and lightweight design.

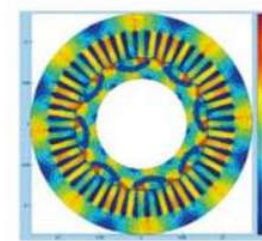

EM Simulation

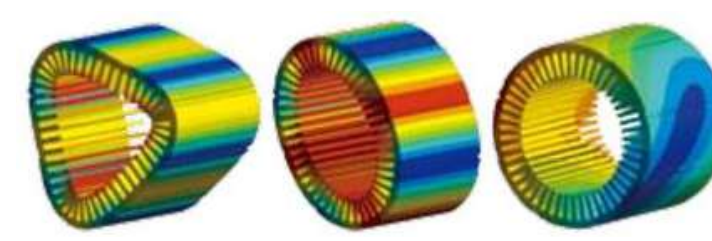

Vibration Modal Analysis

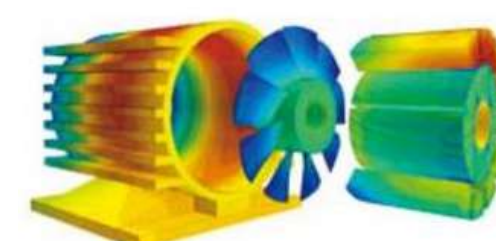

Temperature Field Simulation

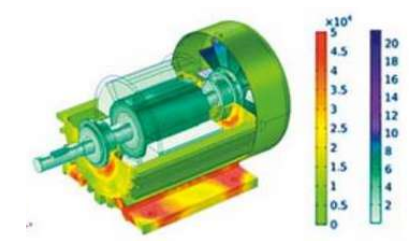

Stress Simulation

- **Motor Development**  
Develop and mass-produce hundreds of electric motor models.
- **Controller Development**  
Develop and mass-produce multiple controller platforms.
- **Transmission Development**  
Develop and mass-produce a variety of transmission systems.
- **Software Development**  
Develop software platforms for pure electric systems and hybrid configurations.
- **System Integration Development**  
Develop a range of systems including pure electric systems and hybrid systems.

# MOTOR FACTORY

## Manufacturing

**4,400,000,000 KM**

Cumulative mileage

**80,000**

Square meters



01

**Motor Stator Automatic Production Line:**  
Capable of automated processes such as wire embedding, shaping, wire tying, and terminal pressing, with a high level of automation.

02

**Motor Rotor Automatic Production Line:**  
Features automated material handling, magnet insertion with full position recognition, press-fitting with pressure and stroke monitoring, and automatic dynamic balancing.

03

**Transmission Housing & Gear Shaft Line:**  
Automated marking, scanning, machining, cleaning, and testing. Robot-assisted material handling for efficiency.

04

**Gear Grinding & Shaping:**  
Advanced processes meet the high demands of new energy vehicle transmissions for speed, efficiency, NVH, and reverse torque.

05

**Connected Equipment:**  
Real-time monitoring of equipment, production orders, and operator data enhances traceability, automates analysis, and improves quality and efficiency.



# ELECTRIC AXLE FACTORY

Our e-axle factory boasts advanced smart manufacturing production lines, soundproof testing chambers, and efficient production management systems. With expertise in key technologies such as DCU, EASR, IESS, and IRBS, our products find extensive applications in mid-size buses, coaches, double-deckers, articulated buses, airport shuttle buses, and heavy-duty trucks.

This year, we launched a new project on a 30-acre site, aimed at creating an intelligent factory focused on the mass production of distributed drive systems. Our goal is to achieve an annual output of 20,000 distributed electric drive axle systems and 100,000 EMB units, further enhancing our global competitiveness.



**14+**  
Years of experience in developing electric vehicle core components

**108+**  
Design specifications and guidelines

**600+**  
PCR and FMEA libraries



Vehicle performance test and simulation



Steer-by-wire test bench

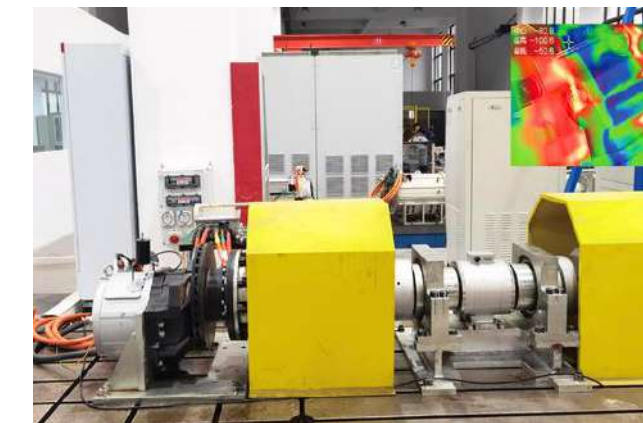

Powertrain performance test bench

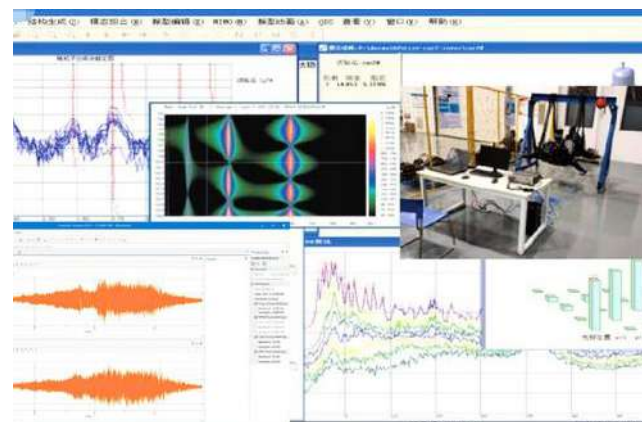

Modal test



Transmission reliability test bench



Vehicle calibration test



# BATTERY FACTORY

## R&D

We have a team of over 200 engineers focused on battery research and development, with more than 30% holding advanced degrees. Our 6,000-square-meter testing center is equipped for comprehensive tests, including temperature cycling, rate charge/discharge, HPPC, EOL, and environmental and safety assessments. All tests are conducted in compliance with CNAS laboratory standards, ensuring the highest quality and precision.

Battery Research Institute	Product Research Institute	Materials Research Institute	R&D Laboratory	Technology Management
<ul style="list-style-type: none"> <li>Product Design</li> <li>Structural Development</li> <li>Process Development</li> <li>Testing</li> <li>Failure Analysis</li> </ul>	<ul style="list-style-type: none"> <li>System Development</li> <li>Structural Design</li> <li>Electrical Design</li> <li>Safety &amp; Reliability</li> <li>Advanced Technology</li> </ul>	<ul style="list-style-type: none"> <li>Cathode Materials R&amp;D</li> <li>Anode Materials R&amp;D</li> <li>Electrolyte R&amp;D</li> <li>Separator R&amp;D</li> <li>Precursor R&amp;D</li> <li>Cell System R&amp;D</li> <li>Cell Mechanism R&amp;D</li> </ul>	<ul style="list-style-type: none"> <li>Pilot Production Line</li> <li>Physical Laboratory</li> <li>Chemical Laboratory</li> <li>Coin Cell Laboratory</li> </ul>	<ul style="list-style-type: none"> <li>Standardization</li> <li>Intellectual Property</li> <li>Project Quality</li> <li>Project Document Management</li> </ul>



### BMS Design & Development

- Develop software for the BMS
- Design and implement control strategies and diagnostic analysis algorithms
- Design the mainboard, control circuits, monitoring circuits, and communication circuits in-house



### Battery Pack Structural and Electrical Design & Development

- Design the battery pack integration structure to accommodate various battery cell types and capacity requirements
- Design electrical circuits and select components, with testing and validation environments that meet industry standards



### Battery System Structural, Electrical, and Monitoring System Design & Integration

- Conduct independent electrical and structural system design
- Integrate third-party systems, devices, and components effectively

# BATTERY FACTORY

## Manufacturing



- ✓ Intelligent Automated Production Line
- ✓ Automotive-Grade Certification + Mass Production Validation
- ✓ Global Expansion Capability

**200% +**

Production Capacity

**13.3% +**

FPY

### Efficient Smart Factory

Leveraging new technologies such as AI, image recognition, machine learning, and predictive algorithms to build a highly efficient factory



### Innovation-Driven Expertise

Our expert-driven engineering and process systems activate the team's creative potential, driving continuous innovation



### Product Quality Control

Comprehensive quality control at every step, supported by fully digitized monitoring and complete quality traceability system



# OUR PROJECTS

\* In adherence to confidentiality agreements, only a curated selection of items is showcased here.



240 kW electric axle  
10-meter bus

360 kW electric axle  
53-ton truck

Air brake compressor  
City bus

320 kW electric axle  
12-meter bus

EV motor  
Mining truck

EV battery  
Loader

AC/DC power supply  
Crane

AC/DC power supply  
Petroleum machinery



EV motor  
Light-duty truck

EV battery  
EV boat

EV motor  
Pick-up

EV motor for upfit  
Concrete mixer

EV motor  
Train

EV motor  
Electric truck

EV battery  
Light-duty truck

EV battery  
Port AGV

# OUR PROJECTS

\* In adherence to confidentiality agreements, only a curated selection of items is showcased here.



EV motor  
Boat

EV battery  
Airport GSE

EV battery  
12-meter bus

Electric axle  
Light truck

Electric axle  
Water truck

EV motor  
Motorcycle

EV motor  
ATV

EV chassis  
Hybrid light truck



EV motor  
Bulldozer

EV motor  
Heavy truck

EV motor  
Light truck

EV motor  
Concrete mixer

Auxiliary inverter  
Semi-truck

EV chassis  
Light truck

EV motor  
Bus

EPS  
Bus



# CONNECT WITH US.

## Email

[inquiry@brogenmotors.com](mailto:inquiry@brogenmotors.com)

## Social Media

 Shanghai OE Industrial Co., Ltd.

 @BrogenEVSolution

## WhatsApp

+86 19352135902

## Wechat

Brogenmotors\_SH

